

**Heavy-duty universal mobile base**

**50-035**  
2 heavy-duty 3" wheels. 2 heavy-duty swivel casters.

**\$129.99**  
reg. \$175.00

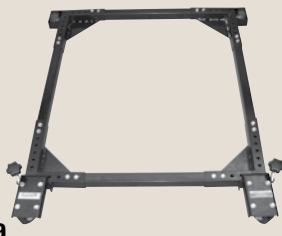

**1000 lb load capacity**

**1" & 2" x 42" belt & 8" disc sander**

**1" and 2" 100 grit sanding belts and 8" 100 grit sanding disc included.** Two belt platens for use with either 1" or 2" x 42" sanding belts. Quick-change belt tension lever. Two built-in 1/2" dust ports. Belt speed of 3100 lin. fpm. Disc speed of 3450 rpm. 1/2 HP motor.

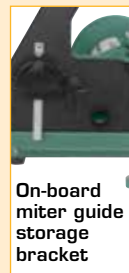

**On-board miter guide storage bracket**



**15-142 M1**  
**\$329.99**  
reg. \$399.00

*Spring / Summer*  
**PROMOTION 2014**

**10" 2 HP cabinet saw (left tilt)**

**Quick release combination riving style splitter and blade guard with anti-kickback pawls and a second European style riving knife also included.** Large 27" x 44" cast-iron table with two extension wings. Cast-iron cabinet mounted trunnions. Dual voltage motor pre-wired for 230 V operation.



**GENERAL "T" fence system**  
Made in Canada



**50-200R M1**  
Aluminum T-fence rip fence system.

**\$1,249.99**  
reg. \$1,650.00

**50-200RC30 M1**  
General "T" fence system (F36T28) with 30" cutting capacity.

**\$1,499.99**  
reg. \$1,850.00

**50-200RC52 M1**  
General "T" fence system (F36T52) with 52" cutting capacity.

**\$1,599.99**  
reg. \$1,950.00

Model shown

**50-200RC52K M1**

General "T" fence system (F36T52) with 52" cutting capacity, table & support legs included.

**\$1,699.99**  
reg. \$2,130.00



**GENERAL "T" fence system**  
Made in Canada

**Cast-iron base for added stability**

Model shown

**50-275RC52K M1**

General "T" fence system (F36T52) with 52" cutting capacity, table & support legs included.

**\$1,999.99**  
reg. \$2,755.00

**10" 3 HP cabinet saw (left tilt)**

**Powerful 3 HP motor with multi-groove V-belt.** Combination riving style splitter and see-through blade guard with anti-kickback pawls, and a second European style riving knife also included. Large precision-ground 44" x 27" cast-iron table with two extension wings. Magnetic safety switch with large stop button.

**50-275RC30 M1**  
General "T" fence system (F36T28) with 30" cutting capacity.

**\$1,799.99**  
reg. \$2,500.00

**50-275RC52 M1**  
General "T" fence system (F36T52) with 52" cutting capacity.

**\$1,899.99**  
reg. \$2,575.00

*Distributed by:*

We reserve the right to correct any typographical and pictorial errors without notice.



www.general.ca

Prices are in effect from  
March 1<sup>st</sup> to August 31<sup>st</sup> 2014



## 15" single surface planer

2 feed speeds: 16 & 20 fpm. Magnetic safety switch with extra-large stop panel and lock-out key. Four-post design provides added stability. Built-in mobile base. 3 HP motor.

**FREE**  
with the purchase  
of 30-115 M1 only

30-050  
  
Knife  
setting jig

30-115 M1  
**\$1,895.99**  
reg. \$2,400.00

30-115HC M1\*  
**\$2,859.99**  
reg. \$3,450.00

\* Same features as model 30-115 M1  
+ Magnum helical head, #125H  
(4 rows, total: 42 inserts).



## 15" single surface planer

2 feed speeds: 16 & 20 fpm. Magnetic safety switch. Triple V-belt drive for greater power. Built-in mobile base. 3 HP motor mounted in cabinet for protection from dust.

**FREE**  
with the purchase  
of 30-125CE M1 only

30-050  
  
Knife  
setting jig

30-125CE M1  
**\$2,114.99**  
reg. \$2,760.00

30-125HC M1\*  
**\$3,199.99**  
reg. \$4,275.00

\* Same features as model 30-125CE M1  
+ Magnum helical head, #125H  
(4 rows, total: 42 inserts).



## 20" single surface planer

2 feed speeds: 16 & 20 fpm. Large cast-iron extension wings. Magnetic safety switch. Built-in mobile base with one-step lock-pedal. 5 HP motor.

**FREE**  
with the purchase  
of 30-300 M1 only

30-050  
  
Knife  
setting jig

30-300 M1  
**\$3,319.99**  
reg. \$4,290.00

30-300 M1\*  
**\$4,439.99**  
reg. \$6,300.00

\* Same features as model 30-300 M1  
+ Magnum helical head, #30300H  
(4 rows, total: 58 inserts).



# Scroll Saws



## 21" & 30" scroll saws

Upper and lower blade guard assembly helps prevent hand / finger contact with the blade. Dust collector table kit for direct dust-extraction hook-up. Switch protection device to prevent unintentional start-up of the saw. Foot switch & stand included. Head tilts 38° left and 45° right, tilting the blade, not the table. 2" Cutting thickness capacity. Variable speed of 400 to 1550 strokes/minutes.



EX-21K (21")

EX-21K (21")  
**\$879.99**  
reg. \$1,195.00

EX-30K (30")  
**\$1,029.99**  
reg. \$1,464.45



EX-30K (30")

Foot switch & stand included with models  
EX-21K & EX-30K only

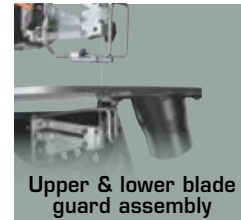

Upper & lower blade  
guard assembly



Switch protection  
device



Dust collector  
hook-up kit

EX-16 (16")  
**\$584.99**  
reg. \$749.00



## 16" scroll saw

Upper and lower blade guard assembly helps prevent hand / finger contact with the blade. Dust collector table kit for direct dust-extraction hook-up. Switch protection device to prevent unintentional start-up of the saw. Head tilts 30° left and 45° right, tilting the blade, not the table. 2" cutting thickness capacity. Variable speed of 400 to 1400 stroke/minutes.



## 20" single surface planer

2 feed speeds: 22 & 28 fpm. Anti-kickback fingers at the front of the in-feed roller to ensure maximum operator safety. Built-in table rollers reduce friction. Equipped with a sectioned in-feed roller and a rubber out-feed roller. 7 1/2 HP motor.

**FREE**  
with the purchase  
of 30-360 M1, M2, M3 only



30-360 M1, M2, M3  
**\$5,019.99**  
reg. \$6,225.00

30-360HC M1, M2, M3\*  
**\$6,299.99**  
reg. \$8,700.00

\* Same features as model 30-360 M1, M2, M3  
+ **Magnum helical head**, #360H  
(4 rows, total: 58 inserts).



30-005HC M1

**\$699.99**  
reg. \$849.00



## 13" planer with helical head

Helical cutter head with 26 reversible two-sided inserts. Pre-set depth stop for repeat cuts at 1/8", 1/4", 1/2" & 3/4". Powerful 2 HP 15 A motor with thermal overload protection.

30-120 M1

**\$1,999.99**  
reg. \$2,650.00



## 7" molder

Magnetic 2-step safety switch to prevent unwanted or unintentional start-up with an extra-large stop panel and lock-out key. Cast-iron table and head. Precision machined heavy-duty cast-iron dovetailed column. Independent, variable speed feed motor provides added control. 7000 rpm cutter head speed. 2 HP motor.

# Router Tables



40-200C  
**\$1,099.99**  
reg. \$1,380.00



## Deluxe router table kit with cast-iron table top

**KIT INCLUDES:**  
**24" x 32" cast-iron table top (#40-075)**  
**Tubular steel stand (#40-085):** Complete with built-in casters, on/off switch, and four adjustable leveling feet.  
**Router lift (#40-125):** Heavy-duty massive router lift with 9 1/4" x 11 3/4" aluminum top plate. Stable 4 post/lift screw design & chain drive lifting system controlling all 4 corners simultaneously.  
**Deluxe router fence (#40-080):** Fence has 2 1/4" dust collection outlet and adjustable scales.  
**Dust collection kit (#40-130):** Under table steel dust enclosure with access door, adjustable air vent, power cord grommet and 4" dust port with 2 1/4" branch inlet.

## Router table package with MDF table



Bench top model

**New!**  
40-100MEP  
**\$399.99**  
reg. \$542.99

**KIT INCLUDES:**  
15 3/4" x 25 5/8" MDF table (#40-047), stand with on/off switch (#40-060), deluxe router fence (#40-065) and 9 1/4" x 11 3/4" Phenolic router plate (#40-114).



Floor model

40-200MEP  
**\$499.99**  
reg. \$662.99

**KIT INCLUDES:**  
24" x 32" MDF table (#40-049), tubular steel stand with on/off switch (#40-085), deluxe router fence (#40-080) and 9 1/4" x 11 3/4" Phenolic router plate (#40-114).

## Cast-iron router table kit for table saws

40-070EK  
**\$399.99**  
reg. \$536.00

**KIT INCLUDES:**  
16" x 27" cast-iron table (#40-070), two adjustable-length steel support legs (#40-068), deluxe 27" router fence (#40-065) and 9 1/4" x 11 3/4" Phenolic router plate (#40-114).



Heavy-duty router lift with 9 1/4" x 11 3/4" aluminum top plate  
40-125  
**\$369.99**  
reg. \$449.00



**New!**  
Stock pusher  
40-120  
**\$79.99**  
reg. \$99.00



9 pcs brass precision template guide set  
40-099  
**\$34.99**  
reg. \$49.95



Vertical feather board  
40-160  
**\$14.99**  
reg. \$19.95



Horizontal feather board (set of 2)  
40-175  
**\$37.99**  
reg. \$59.95



**90-140 M1**  
**\$679.99**  
 reg. \$850.00



**14" wood cutting bandsaw**  
 3/8" blade included. Cast-iron frame and precision-balanced aluminum wheels. Safety lock-out switch with removable key. 2 blade speeds: 1630 & 2730 fpm. 1 HP motor.

**Optional riser attachment**  
 For 90-140 M1 only

**90-130A**  
**\$87.99**  
 reg. \$140.00



**90-125 M1**  
**\$999.99**  
 reg. \$1,200.00



**Excalibur**  
 BY GENERAL INTERNATIONAL  
 Deluxe rip fence system

**14" wood cutting bandsaw**  
 3/8" blade included. Cast-iron frame & precision-balanced aluminum wheels with replaceable rubber tires. Rip fence & miter gauge included. 2 blade speeds: 1800 & 3000 fpm. Blower device. 1 HP motor.

**Optional riser attachment**  
 For 90-125 M1 only

**90-130**  
**\$87.99**  
 reg. \$140.00



**Excalibur**  
 BY GENERAL INTERNATIONAL

**Universal bandsaw rip fence system**  
**21" fence.** Fits on General International models: 90-100, 90-125, 90-140 & 90-170.

**90-075A**  
**\$149.99**  
 reg. \$185.00

# Saws

**50-560A M1**  
**\$6,399.99**  
 reg. \$7,885.00



**INCLUDED**  
 with the purchase of 50-560A M1 only

50-565A  
 Outrigger slider support

**10" scoring saw with built-in sliding table**  
 (right tilt)

Can be used as a regular saw, but includes a built-in sliding table for stable effortless crosscuts & a separate scoring blade for chip-free cuts in melamine & laminates. Anodized European style sliding table. Separate safety lock out switch for main motor & scoring motor. Solid cast-iron table with anodized aluminum coating. Heavy-duty cabinet-mounted cast-iron trunnions. Precision-built rip fence system with 50" guide rails. 3 HP motor.

Dust collection from cabinet & blade

See-through blade guard with splitter & anti-kickback pawls

**50-755 M1**  
**\$3,569.99**  
 reg. \$4,300.00



**12" radial arm saw**  
 Powerful 2 HP 220V single phase TEFC motor. Cast-iron frame, heavy steel column and sturdy stand. Tilting pivoting head allows for crosscuts, bevels, miters & rip cuts. Precision adjustable indexing with positive stops at 90°, 45° and 22.5°. 5/8" arbor with 1" spacer bushing included.

**3 piece - 10" x 5/8" carbide blade assortment with deluxe carrying case**  
**55-300S**  
**\$89.99**  
 reg. \$191.00



**INCLUDED**  
 Carpenters pencil - 4 pack

- (1) 24 tooth - rip blade (55-100).
- (1) 50 tooth - combination blade (55-105).
- (1) 80 tooth - fine cut-off blade (55-115).
- (1) Convenient & sturdy storage case.

**Mobile base for table saws with extension table and legs**  
**900 lbs capacity**



**50-030**  
**\$189.99**  
 reg. \$240.00

**7 piece - 8" deluxe DADO blade set**  
 (2) 24 tooth exterior blades. Max. 6000 RPM. Makes 1/8" to 1 3/16" grooves. Anti-kickback design. Convenient & sturdy wooden storage case included.



**55-185**  
**\$159.99**  
 reg. \$249.00

**Tenoning jig**  
 Perfect fit on right or left tilt table saws.



**50-050**  
**\$149.99**  
 reg. \$196.00

**10" combination blade - 40 tooth**  
**55-040**  
**\$24.99**  
 reg. \$40.00





**90-170B M1**  
**\$1,594.99**  
 reg. \$1,950.00

**Excalibur**  
 BY GENERAL INTERNATIONAL

**Deluxe rip fence system**

**Deluxe 14" wood cutting bandsaw**  
 12" resaw capacity. Safety foot brake stops blade & motor. Dynamically balanced heavy cast-iron wheels. 2 cutting speeds, 2300 & 3250 fpm, for excellent results in either hard or soft woods. 3/4" blade included. 1 1/2 HP motor.



**90-320 M1**  
**\$3,499.99**  
 reg. \$4,200.00

**Excalibur**  
 BY GENERAL INTERNATIONAL

**Deluxe rip fence system**

**17" wood / metal bandsaw**  
 Electronic variable speed digital inverter. Dynamically balanced cast-iron wheels. Solid, high quality, precision machined, ribbed cast-iron table with 5° left and 45° right tilting action. Blade speeds: 540 to 3600 fpm (wood) & 100 to 650 fpm (metal). 2 HP motor.



**Power feeders**

**20-100 M1**  
**\$419.99**  
 reg. \$519.00

**20-200 M1**  
**\$649.99**  
 reg. \$800.00

Fully adjustable. Variable speeds 6.5 to 40 fpm in forward or reverse. 1/8 HP motor

3 rollers. 4 speeds: 20, 26, 33 & 43 fpm. 1/4 HP motor.



**Excalibur miter gauge**

Newly designed pointer/angle indicator provides better visibility to set precision fractional angles. Sliding stop flips up out of the way when not in use. Extension arm assembly makes it possible to quickly and easily find any angle and lock it securely in place. Quickly reverse the guide for left or right hand use.



**50-EB3**  
**\$119.99**  
 reg. \$210.00



**General-T fence systems**

**F36T28**  
 30" cutting capacity.  
**\$334.99**  
 reg. \$435.00

**F36T52**  
 52" cutting capacity.  
**\$399.99**  
 reg. \$510.00



Pivots arm away or removes in seconds.

**50-EXBC10**  
**\$399.99**  
 reg. \$550.00



**10" overarm blade cover system with dust collection capability**  
 Unique design mounting bracket: pivots arm away or removes completely in seconds. 4" main boom and 3" inner boom. Flexible 3" hose connects the blade cover to the boom.

**50-SLT40P**  
**\$1,249.99**  
 reg. \$1,500.00

**50-SLT60P**  
**\$1,459.99**  
 reg. \$1,790.00

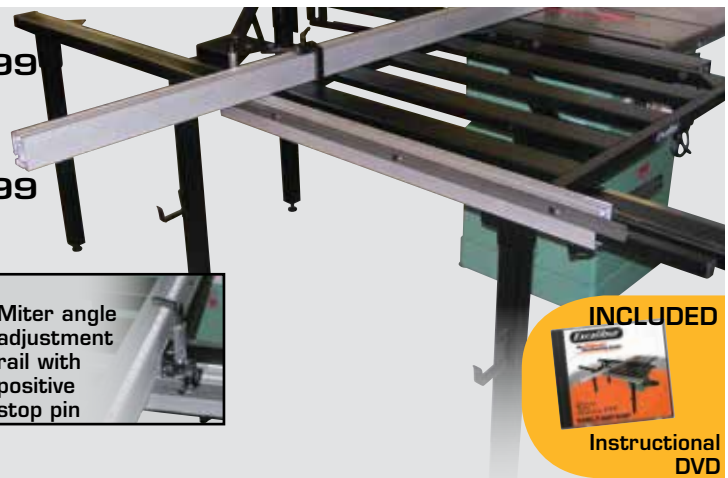

Onboard fence storage mounts



Miter angle adjustment rail with positive stop pin



**INCLUDED**  
 Instructional DVD

**Sliding tables**

Fits on most 10" to 14" table saws. Easy to adjust, extruded aluminum miter fence for accurate miters from 0° to 50° (50-SLT40P) or 0° to 45° (50-SLT60P). Cut up to 49"\* (50-SLT40P) or 72"\* (50-SLT60P) with the crosscut fence positioned at the rear of the table. Crosscut and miter up to 28"\* (50-SLT40P) or 49"\* (50-SLT60P) with the fence at the front of table.

\* Depending on the positioning of the main mounting bracket on your saw.

25-024  
**\$224.99**  
 reg. \$349.00



Wood lathe not included



**Mini-lathe duplicator**

Fits most 6" to 14" swing bench top lathes with cast bedways. Extruded aluminium base and carriage. Smooth handwheel controlled chain drive system.

25-036  
**\$419.99**  
 reg. \$570.00

2 Wood lathe not included



**36" wood lathe duplicator**

Fits most 12" to 22" floor model lathes with cast bedways. Extruded aluminum base and carriage. Smooth handwheel controlled rack & pinion system. High speed steel cutter.

25-195N  
**\$194.99**  
 reg. \$249.00

25-196  
**\$109.99**  
 reg. \$140.00



**Steel support stand for Maxi-Lathe (25-195N) & bed extension (25-196)**

Fits General International models: 25-100, 25-114, 25-114QC & 25-200

**BONUS**



1 wine stopper hardware kit

25-005  
**\$49.99**  
 reg. \$79.00



**Pen turning starter kit**

Starter kit includes: 1 pen turning hardware kit for each of the following pen styles, 5 assorted wooden pen blanks & 1 bonus wine stopper hardware kit.

# Lathes

25-010 M1  
**\$239.99**  
 reg. \$329.00

**BONUS**  
 with the purchase of 25-010 M1 only



Pen turning mandrel set



**Pen turning mini-lathe**

Designed and built specifically for turning pens and other smaller hobby type projects. Quick lock control levers easily position tool rest. Extruded aluminum frame, head and tailstock. Maximum distance of 12" between centers. 3 speeds: 1350, 2250 & 3500 RPM. 1/5 HP motor.

16018-2-M1  
**\$2,499.99**  
 reg. \$4,200.00

Made in CANADA



Limited Quantities  
 While supplies last

**18" x 38" variable speed wood lathe**

High quality ribbed cast-iron headstock, tailstock, and bed. 21" swing over gap capacity. 500 to 3000 rpm variable speed. 38" distance between centers. Powerful, totally enclosed, fan cooled industrial 1 HP motor.

26020-1-M2  
**\$3,699.99**  
 reg. \$6,590.00

Made in CANADA



Limited Quantities  
 While supplies last

**20" x 38" variable speed wood lathe**

High quality ribbed cast-iron headstock, tailstock, and bed. 24 1/2" swing over gap capacity. 375 to 3300 rpm variable speed. 38" distance between centers. Powerful, totally enclosed, fan cooled industrial 2 HP motor.

25-250  
**\$59.99**  
 reg. \$126.00

**5 piece wood turning mini-chisel set**

Includes:

- 1/8" gouge (#25-255)
- 1/4" gouge (#25-260)
- 3/32" parting tool (#25-265)
- 1/4" round nose scraper (#25-270)
- 1/4" skew chisel (#25-275)
- wooden case (#25-280)



*Designed specially for smaller turning.*

25-210  
**\$199.99**  
 reg. \$310.00

**4 piece wood turning chisel set**

Includes:

- 3/4" diamond parting tool (#25-215)
- 1/2" round nose scraper (#25-220)
- 1" skew chisel (#25-225)
- 1/2" bowl gouge (#25-230)
- wooden case (#25-235)



40-010  
**\$89.99**  
 reg. \$99.00



**12" dovetail jig**

**New clamping system for greater accuracy.** The template offers a more stable platform for router as the height is lockable. Handles stock up to 12" wide and from 5/16" to 1 1/4" thick. Comes with 1/2" aluminum template (40-016).



**14" x 17" variable speed "Maxi-Lathe VF"**

**Quick release belt tension lever for faster, easier speed changes.** Forward or reverse spindle rotation selector switch. Digital spindle speed display. Maximum of 17" between centers. 3 variable speed ranges: 250 to 800, 550 to 1700 & 1200 to 3600 rpm. 3/4 HP motor.

25-114QC M1  
**\$654.99**  
 reg. \$800.00

**Optional 23" bed extension**  
 For maximum distance of 40" between centers.  
 For 25-114QC M1 only



25-116  
**\$210.99**  
 reg. \$260.00



25-650ABC M1  
**\$2,299.99**  
 reg. \$2,990.00

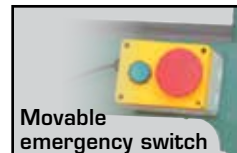

Movable emergency switch



14" tool rest & a 6" face plate included



**12" x 17" variable speed "Maxi-Lathe VS+"**

**Headstock pivots 360° with 180° positive stop for out-board turning.** Forward/reverse switch. Digital spindle speed display. Quick lock control levers easily position tool rest. Maximum distance of 17 3/16" between centers. 3 variable speed ranges: 300 to 900, 600 to 1800 & 1200 to 3600 rpm. 3/4 HP motor.

25-200 M1  
**\$829.99**  
 reg. \$1,000.00

**Optional 32" bed extension**  
 For maximum distance of 49" between centers.  
 For 25-200 M1 only

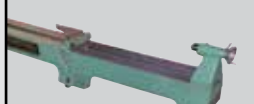

25-205  
**\$210.99**  
 reg. 260.00

**16" x 43" electronic variable speed wood lathe**

**Specifically designed and built for professionals who want superior performance.** Headstock swivels 360° with positive stops at 0°, 45°, 90°, 135°, 180° & 270° for outboard turning. Electronic inverter for variable speed adjustment between 45 & 3750 rpm. Forward or reverse rotation. Low/High speed change lever for quick belt position changing. Quiet, highly efficient, low power consumption 2 HP motor.



15-155 M1  
**\$1,329.99**  
 reg. \$1,650.00



**13" horizontal single drum sander - 1 1/2 HP**

6 to 20 fpm variable feeding speed (conveyor belt). Heavy-duty open steel stand. Independent switches with removable safety key for both conveyor motor and main motor. 1 1/2 HP motor.

15-150 M1  
**\$1,899.99**  
 reg. \$2,350.00



**24" horizontal single drum sander - 2 HP**

3 to 20 fpm variable feeding speed. Steel frame and heavy-duty base for greater stability. High quality conveyor belt for longer service life. Magnetic safety switch. 2 HP motor.

15-250 M1  
**\$2,389.99**  
 reg. \$2,990.00



**24" horizontal double drum sander - 3 HP**

Two 5" diameter aluminum drums. High quality conveyor belt for long service life. Magnetic safety switch. 3 to 20 fpm variable feeding speed (conveyor belt). 3 HP motor.

# Sanders & Grinders

15-005S M1  
**\$1,099.99**  
 reg. \$1,349.00

**6" x 89" oscillating vertical edge belt sander**

Oscillating feature. Sanding belt operates at any angle from horizontal to vertical. Graphite covered steel platen for reduced friction and extended belt life. 1 1/2 HP motor.

**6" x 89" edge belt sander**  
 Same features as model 15-005S M1 without oscillating feature.

15-005 M1  
**\$979.99**  
 reg. \$1,259.00



Entire head moves up and down (not just the belt) to maximize belt life and minimize tracking adjustments. Inward and outward tilting adjustable height steel auxiliary end table. Graphite backing reduces friction for longer belt life.

**6" x 108" oscillating vertical edge belt sander**

Oscillating feature. Tables can be adjusted up or down for full belt use. Graphite backing reduces belt friction for longer belt life. Dynamically balanced 7" rubber drive roller and crowned 3" idler roller to ensure solid belt tracking. 2 HP motor.

**6" x 108" edge belt sander**  
 Same features as model 15-010S M1 without oscillating feature.

15-010 M1  
**\$1,899.99**  
 reg. \$2,375.00



15-010S M1  
**\$2,259.99**  
 reg. \$2,750.00

15-210 M1  
**\$2,999.99**  
 reg. \$3,995.00

**6" x 108" oscillating vertical edge belt sander**

3250 lin. fpm belt speed. 2 HP motor.

15-310 M1  
**\$4,499.99**  
 reg. \$5,900.00

**9 1/2" x 135 1/2" oscillating vertical edge belt sander**

4000 lin. fpm belt speed. 3 HP motor.



15-232 M1  
**\$209.99**  
 reg. \$269.00



**1 3/4" x 32" belt sander / 6" grinder**

Belt sander operates horizontally, vertically and can be locked at any angle in between. 3450 rpm grinding speed. 4900 fpm belt speed. 1/2 HP motor.

15-825 M1  
**\$179.99**  
 reg. \$225.00



**8" low speed bench grinder**

Low 1725 rpm. Double sealed ball-bearing construction. Adjustable cast tool rests. 1/2 HP motor.

15-660 M1  
**\$149.99**  
 reg. \$190.00



**6" variable speed bench grinder**

Variable speed from 2000 to 3450 rpm for grinding or sharpening. Double sealed ball-bearing construction. 110 V motor.

Heavy-duty 34" stand for 6", 8" & 10" bench grinders

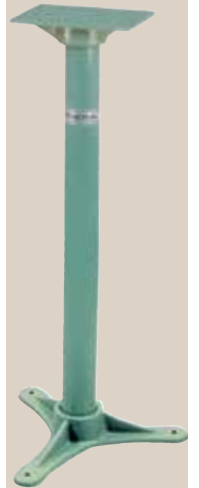

15-700  
**\$69.99**  
 reg. \$85.00



15-205 M1  
**\$1,459.99**  
 reg. \$1,799.00



**15" disc sander**

Powerful 2 HP motor with built-in brake. Rear wraparound and front 1/2 disc steel guards. 0° to 45° tilting cast-iron table. Magnetic safety switch with extra-large stop panel and lock-out key.

15-015 M1  
**\$969.99**  
 reg. \$1,275.00

**6" x 48" belt & 12" disc sander**

Sanding belt operates at any angle from horizontal to vertical. Tilting cast-iron tables. Belt speed of 1570 lin. fpm. Disc speed of 2000 rpm. 1 HP, 110/220 V motor.



Lower belt guard



50-025  
**\$67.99**  
 reg. \$95.00



500 lb load capacity

**Universal mobile base**

Heavy-duty 3" wheels. Rubber levelling feet (2). Adjustment in 1" increments.

15-035DC M1  
**\$1,429.99**  
 reg. \$1,800.00

**6" x 48" belt & 12" disc sander with built-in dust collector**

Sanding belt operates at any angle from horizontal to vertical with positive stops at 90° & 45°. Two large surface, cast-iron, tilting tables for unlimited sanding operations. Heavy-duty enclosed cabinet. 2250 lin. fpm belt speed. 1750 rpm disc speed. Heavy-duty model - 365 lbs. 1 1/2 HP, 110/220 V motor.



Built-in dust collector



15-220 M1  
**\$489.99**  
 reg. \$585.00



Tilting table

**Oscillating spindle sander bench top model**

**Precision ground cast-iron tilting table.** 29 oscillations per minute. 5 interchangeable spindles including 1/4", 1/2", 3/8", 1 1/2" & 2". 1720 rpm spindle speed. 1/2 HP motor.

15-020 M1  
**\$1,374.99**  
 reg. \$1,789.00



Tilting table

**Oscillating spindle sander floor model**

**Heavy-duty oil bath gearbox.** 75 oscillations per minute. 10 interchangeable spindles including 1/4", 3/8", 1/2", 5/8", 3/4", 1", 1 1/2", 2", 3" & 4". 1725 rpm spindle speed. 1 HP motor.

10-630  
**\$369.99**  
 reg. \$495.00



**30" oscillating pedestal fan - 3 speeds**

**Adjustable height (69 1/4" to 93 3/4").** Wide stable steel base plate. Quiet operation. 3 speed settings : 800, 950 & 1100 rpm. 1/4 HP motor.

# Sanders, Jointers & Shapers

80-100L M1  
**\$899.99**  
 reg. \$1,100.00

**6" closed base jointer**

**55 1/4" long tables.** Large surface, ground cast-iron tables. Cast-iron fence with 90° & 45° positive stops. Independent in-feed and out-feed table adjustment handwheels. 5000 rpm cutter head speed. 1 HP motor.

**6" closed base jointer with Magnum helical head**

Same features as model 80-100L M1+ Magnum helical head, #100H (4 rows, total: 16 inserts).

80-100LHC M1  
**\$1,399.99**  
 reg. \$1,800.00



80-200L M1  
**\$2,099.99**  
 reg. \$2,600.00

**8" jointer**

**74 7/8" long tables.** Large surface, ground cast-iron tables. Independent in-feed and out-feed table adjustment handwheels. Magnetic switch for added safety. 5500 rpm cutter head speed. 2 HP motor.

**8" jointer with Byrd style helical head**

Same features as model 80-200L M1+ Byrd helical head, #200HB (4 rows, total: 36 inserts).

80-200LHC M1  
**\$2,749.99**  
 reg. \$3,350.00



480-1-M2  
**\$2,599.99**  
 reg. \$4,625.00



Limited Quantities  
 While supplies last



**Deluxe 8" jointer**

**74" long tables.** Precision-machined and polished, high quality, heavy-duty, ribbed cast-iron frame. One-piece, top-quality machined steel cutter head, mounted on 2 sealed, permanently lubricated bearings. Highly accurate guide fence. 1 1/2 HP motor.

**Deluxe 8" jointer with Magnum helical head**

Same features as model 480-1-M2 + 2 HP motor and Magnum helical head, #485H (4 rows, total: 22 inserts).

480-1-M2HC  
**\$3,299.99**  
 reg. \$5,570.00





40-250 M1  
**\$1,649.99**  
 reg. \$2,150.00



**3/4" spindle shaper**  
 1/4" & 1/2" router bit adapters included.  
 2 spindle speeds with reverse: 8000 & 10,000 rpm. Fence system / cutter head guard includes a cutter guard, spring hold-downs and a built-in 4" dust collection outlet. 3 HP motor.

40-350 M1  
**\$3,529.99**  
 reg. \$4,500.00



**1 1/4" production shaper**  
 4 spindle speeds with reverse: 4000, 6000, 8000 & 10,000 rpm. Magnetic switch with thermal overload protection. Built-in retractable caster system. 5 HP motor.

40-450 M1, M2, M3  
**\$5,199.99**  
 reg. \$6,550.00



**1 1/4" heavy-duty production shaper**  
 5 spindle speeds with reverse: 3000, 4000, 6000, 8000, & 10 000 rpm. Independent left and right micro-adjustable fences, with a cutter guard, spring hold-downs and a built-in 4" dust collection outlet. Magnetic switch with thermal overload protection. 5 HP motor (M1) / 7 1/2 HP motor (M2 & M3).



80-075L M1  
**\$769.99**  
 reg. \$890.00



**6" jointer**  
 55 1/4" long tables. Large surface, ground cast-iron tables. Heavy-duty, three-knife cutter head. Jack-screw system for quick, easy knife adjustment. 5000 rpm cutter head speed. 1 HP motor.

80-250XHC M1  
**\$3,799.99**  
 reg. \$5,650.00

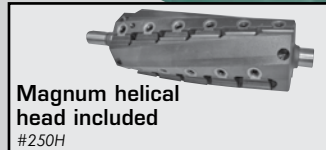

Magnum helical head included  
 #250H

80-225HC M1  
**\$3,569.99**  
 reg. \$4,400.00

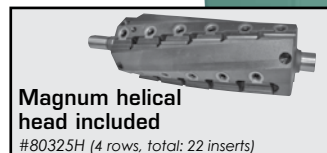

Magnum helical head included  
 #80325H (4 rows, total: 22 inserts)

**8" parallelogram jointer**  
 Large surface 82 7/8" cast-iron tables. Heavy-duty center-mounted cast-iron fence with 45°, 90° and 135° positive stops. Precision four point parallelogram table adjustment system. Magnetic safety switch mounted above the in-feed table for quick, easy access. 5000 rpm cutter head speed. 3 HP motor.

**10" jointer**  
 Large surface, precision ground 84 1/4" cast-iron tables with built-in rabbeting ledge. Handwheel adjustable in-feed and out-feed tables mounted on dovetailed ways. Accurate depth of cut scale in inches. Two way tilting fence with positive stops at 45° and 90°. 5500 rpm cutter head speed. 3 HP motor.

**75-040 M1**  
**\$389.99**  
 reg. \$560.00



4 chisel & bit sets included

Convenient tool holder

**5/8" hollow chisel mortiser**  
 1/4", 5/16", 3/8" & 1/2" chisel & bit sets included. Includes sleeves for both 5/8" and 3/4" chisel shanks. Large table with telescopic extensions. Heavy-duty cast-iron construction. 1/2 HP TEFC motor.

**75-050T M1**  
**\$629.99**  
 reg. \$790.00



4 chisel & bit sets included

Tilting head

**5/8" hollow chisel mortiser**  
 1/4", 5/16", 3/8" & 1/2" chisel & bit sets included. Includes sleeves for both 5/8" and 3/4" chisel shanks. Features a tilting head (30° left & right) with a 180° swivel. 1/2 HP TEFC motor.

**75-075 M1**  
**\$1,249.99**  
 reg. \$1,590.00



4 chisel & bit sets included

Adjustable swivel fence

**1" hollow chisel mortiser**  
 1/4", 3/8", 1/2" & 3/4" chisel & bit sets included. Heavy-duty cast-iron construction. Lateral and longitudinal table movement. Tilting head and swivel fence. 1 HP motor.

**Optional closed stand for mortiser**  
 For 75-050T & 75-075 only



**75-070**  
**\$290.99**  
 reg. \$340.00

**Set of 2 mortiser table rollers**



**75-055**  
**\$34.99**  
 reg. \$56.85

# Mortisers & Drill Presses

**14" drill presses**  
 5/8" chuck with key, laser pointer & see-through chuck guard included. Rotating, 45° tilting, crank-operated worktable with quick release clamp. Forced opening line interrupter switch, requires machine restart in case of power failure or circuit interruption. Built-in lamp illuminates the drilling area (bulb not included). 12 spindle speeds: 280 to 3000 rpm. 1/2 HP motor.

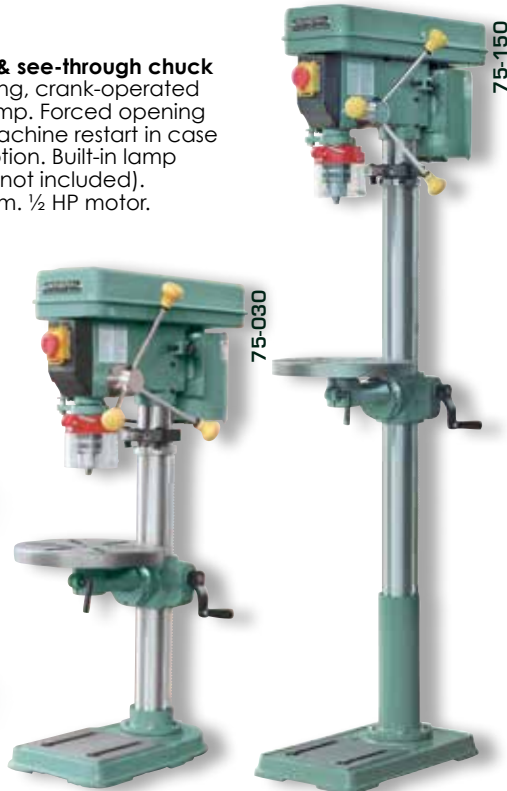

**75-030 M1**  
 Bench top model  
**\$349.99**  
 reg. \$430.00

**75-150 M1**  
 Floor model  
**\$384.99**  
 reg. \$470.00

**75-550 M1**  
**\$629.99**  
 reg. \$780.00



**Radial arm drill press**  
 5/8" chuck with key & see-through chuck guard included. 3 1/8" spindle travel. 9 spindle speeds: 295 to 3580 rpm. Table swivel 360°. Forced opening line interrupter switch, requires machine restart in case of power failure or circuit interruption. Table extension provides additional support. 1/2 HP motor.

**Portable pocket hole jig**  
 Adjustable variable hole-to-centerline distances allows for different hole placement depending on width of stock. Cast base with 4 mounting holes. Durable 3/8" step drill bit with adjustable depth stop collar. Kit includes 25 each 3/8", 1", 1 1/4", 1 1/2" self-tapping screws.



**70-110**  
**\$79.99**  
 reg. \$127.00

**Heavy-duty drill press chuck guard**  
**\$127.99**  
 reg. \$185.00

**70-155** (55 mm):  
 for 75-025, 75-030, 75-125, 75-150, 75-160 & 75-550

**70-165** (65 mm):  
 for 75-100 & 75-200

**70-175** (75 mm):  
 for 75-260, 75-500 & 75-700



**Laser pointer for drill press**



**70-300**  
**\$14.99**  
 reg. \$25.40



Shown with  
drill bits  
(not included)

75-440 M1  
**\$1,779.99**  
reg. \$2,200.00

### 13 spindle boring machine

Fully adjustable fence system with easy to read scales in both inches and metric. Work stops on either end of the fence allow operator to line up work from the left or right for performing parallel boring patterns. Open base steel stand included. 3450 rpm spindle speed. Powerful 1 1/2 HP motor delivers plenty of power and speed for multiple hole boring even in the toughest laminates.

**INCLUDED**  
with the purchase  
of 75-450A M1 only

Flip down  
hinge insertion  
plate included.

75-450 M1  
**\$1,849.99**  
reg. \$2,400.00

### Hinge boring / Inserting machine

Standard blum style hinge boring kit with 1 x 35 mm and 2 x 8 mm bits included. 4 quick-set workpiece stops included. Large fence with two extension bars, extends to accommodate stock from 66 1/8" to 105 1/2". 3450 rpm spindle speed. 1 HP motor delivers plenty of power and speed for hinge boring even in the toughest laminates.



75-200RC M1  
**\$549.99**  
reg. \$730.00



Line  
interrupter  
switch

**17" drill press**  
5/8" chuck with key, laser pointer & see-through chuck guard included. Rotating, 45° tilting, crank-operated worktable with quick release clamp. Forced opening line interrupter switch, requires machine restart in case of power failure or circuit interruption. 12 spindle speeds: 340 to 2800 rpm. 3/4 HP motor.



75-260 M1  
**\$759.99**  
reg. \$975.00

### 17" extended stroke drill press

3/4" chuck with key, laser pointer & see-through chuck guard included. Extra long 6" quill stroke drills deeper than most drill presses. Large front mounted paddle style stop switch with lock-out safety feature to prevent unwanted or unintentional start-up. 12 spindle speeds: 255 to 2750 rpm. 1 HP motor.

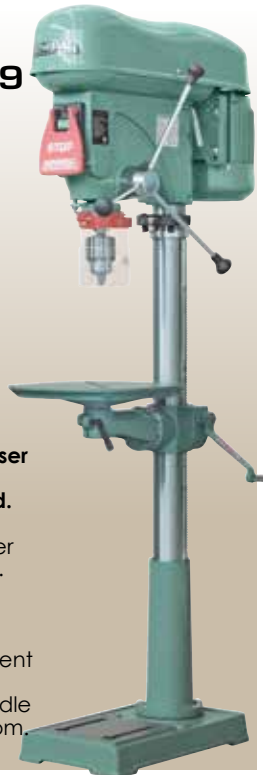

### 22" drill press

3/4" chuck with key, laser pointer & see-through swing-away chuck guard with safety Interlock – shuts off automatically when opened. Cast-iron pulleys reduce vibration. Large front mounted paddle style stop switch with lock-out safety feature to prevent unintentional start-up. Industrial 1 HP motor.



75-500 M1  
**\$959.99**  
reg. \$1,270.00

### Mortising attachment kit Convert almost any drill press into a mortiser in minutes!

Contents: Mounting hardware. Cast-iron chisel holder. Guide fence with workpiece hold down. 4 of the most commonly used mortising chisel and bit sets with 5/8" bit shank x 1/4", 5/16", 3/8" & 1/2". Includes 52, 55, 58, 60, 65 and 66 mm adapter bushings.



70-905  
**\$149.99**  
reg. \$219.00

40-946 M1

**\$7,999.<sup>99</sup>**

reg. \$9,500.<sup>00</sup>

\* Shown with optional 40-945 dust collection adapter kit.



### 24" x 36" CNC carving machine

Pendant style hand-held controller. Easy to learn i-Picture programming software. Large user friendly control panel with LCD display, keypad and USB 2.0 port for easy file transfers. Positional accuracy up to 0.001 inches & variable cutting speeds up to 118" per minute. High-frequency, 1 HP 24,000 RPM variable speed spindle and automatic on/off control. Aluminum table with integrated hold down clamps. Tool kit with starter cutting tools included. No external operating PC required. Sturdy open base steel stand included.



## Cnc Carving Machines



40-913 M1 - 13" x 18"

**\$2,349.<sup>99</sup>**

reg. \$2,895.<sup>00</sup>



40-915X M1 - 15" x 20"

**\$4,699.<sup>99</sup>**

reg. \$5,250.<sup>00</sup>



## i-Carver™

### CNC carving machines

Pendant style hand-held controller. Easy to learn i-Picture programming software. Large user-friendly control panel with LCD display, keypad and USB 2.0 port for easy file transfers. Positional accuracy up to 0.001" & variable cutting speeds up to 118" per minute. Aluminum table with integrated hold down clamps. Tool kit with starter cutting tools included. No external operating PC required. Unlimited and ongoing technical support.

40-918 for model 40-913

**\$999.<sup>99</sup>**

reg. \$1,235.<sup>00</sup>

**Optional safety enclosure**  
Ideal for educational users. Impact resistant Lexan™. Safety interlock door (auto-shut-off).

40-919X for model 40-915X

**\$1,159.<sup>99</sup>**

reg. \$1,375.<sup>00</sup>



40-918 shown

40-912 for model 40-913

**\$189.<sup>99</sup>**

reg. \$229.<sup>00</sup>

40-914 for model 40-915X

**\$189.<sup>99</sup>**

reg. \$239.<sup>00</sup>

**Optional dust collection adapter kit**



40-912 shown

**Optional stand**



40-903 for model 40-913

**\$219.<sup>99</sup>**

reg. \$280.<sup>00</sup>

40-905 for model 40-915X

**\$244.<sup>99</sup>**

reg. \$320.<sup>00</sup>

40-928 for model 40-915X

**\$279.<sup>99</sup>**

reg. \$299.<sup>00</sup>



**Optional CNC tooling kit**



10-050 M1

**\$299.99**

reg. \$379.00



**Portable dust collector  
-1 HP**

**Airflow capacity 700 cfm\***. Dust hood rotates 360°. Adjustable multi-position steel support arm to accommodate a variety of different machines or applications.

10-005 M1

**\$319.99**

reg. \$439.00



**Dust collector - 1 HP**

**Airflow capacity 647 cfm\***. Sound rating 75 to 80 dB. Equipped with washable, extra-fine 2 micron filter bag.

10-030CF M1

**\$399.99**

reg. \$575.00



**Dust collector with  
canister filter - 1 HP**

**Airflow capacity 506 cfm\***. Sound rating 80 to 85 dB. Equipped with high efficiency 1 micron canister filter.

# Dust Collectors

\* All cfm ratings tested under resistance to simulate typical shop usage.

10-105ACF M1

**\$679.99**

reg. \$950.00

**Dust collector - 1 1/2 HP  
with canister filter**

**Airflow capacity 1100 cfm\***. Sound rating 80 to 85 dB. Equipped with 1 micron canister filter.

**Dust collector - 1 1/2 HP**

Same features as 10-105ACF with washable, extra fine 2 micron filter bag replacing canister filter.



10-105A M1

**\$469.99**

reg. \$650.00



10-210ACF M1

**\$1,329.99**

reg. \$1,900.00



**Dust collector - 3 HP  
with canister filter**

**Airflow capacity 2280 cfm\***. Sound rating 85 to 95 dB. Equipped with 1 micron canister filters.

10-110ACF M1

**\$874.99**

reg. \$1,150.00

**Dust collector - 2 HP  
with canister filter**

**Airflow capacity 1550 cfm\***. Sound rating 80 to 90 dB. Equipped with 1 micron canister filter.

**Dust collector - 2 HP**

Same features as 10-110ACF with washable, extra fine 2 micron filter bag replacing canister filter.



10-110A M1

**\$619.99**

reg. \$820.00



**Dust collector - 2 HP**

Same features as 10-210ACF with washable, extra fine 2 micron filter bags replacing canister filters.



10-210A M1

**\$869.99**

reg. \$1,275.00

10-600CI M1

**\$459.99**

reg. \$625.00



### "SUPER TURBO"

#### Air cleaning system

**Airflow Capacity of 700, 900, 1250 cfm.**

Superior 2 stage filtration system includes a disposable, pleated outer filter and a 3 pocket inner filter. 5 preprogrammed timer settings (2, 4, 6, 8 hours & continuous). Includes filter cleaning sensor with indicator light. 1/2 HP motor.

50-166

**\$189.99**

reg. \$229.00

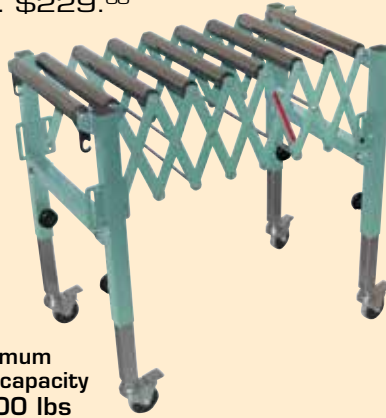

**Maximum load capacity of 200 lbs**

#### Flexible expandable roller stand

**Adjustable height from 23" to 36".** 9 nickel-plated 1 1/2" x 13 3/4" rollers. 50" maximum expanded length. 14 3/4" compacted length. 4" wheels with locking foot levers.

50-167S

**\$329.99**

reg. \$398.00



**Maximum load capacity of 400 lbs**

#### Flexible expandable 2-way heavy-duty roller stand

**Adjustable height from 24 1/4" to 37".** 9 nickel-plated 2 1/4" x 20" 2-way rollers. 51 1/2" maximum expanded length.

Printed in Canada



10-330

**\$59.99**

reg. \$69.00

#### Cyclonic tank kit

Ideal for small shops: Can be used with any shop vacuum or small dust collector with 1 1/2", 2 1/2" or 4" inlets, to create a portable 2-stage dust collection system.



#### Included accessories:

- (1) 6 gallon caster-mounted drum.
- (1) 2-stage cyclone/separator lid.
- (2) Hoses with 3 x 2 1/2" adapter fittings.
- (1) 2 1/2" - 4" reducer fitting.
- (1) 1 1/2" - 2 1/2" reducer fitting.
- (1) 4" clamp.
- (1) 2 1/2" clamp.

25' (7.5 m) measuring tape



99-500  
**\$6.99**  
reg. \$10.50

10-715 M1

**\$199.99**

reg. \$245.00



#### Portable down draft table

**4" dust port connects to your shop dust collector.** 18 1/2" x 35 1/2" table with internal baffles. 6 adjustable stops. Sturdy steel frame and lightweight design.

10-300 M1

**\$384.99**

reg. \$465.00

#### 10 gallon wet / dry vacuum cleaner

**Stainless steel tank 10 gallon capacity.**

Rated for heavy-duty maintenance & janitorial use. 2 stage air filtration. 1/2 HP motor with 2 speeds.

#### Included accessories:

- Flexible 6' hose with curved end pipe (#10-306).
- 2 piece extension wand (#10-309).
- Crevice nozzle (#10-310).
- 12" wide brush nozzle (#10-314).
- Professional wet nozzle (#10-323).
- Canister filter (#10-332).
- Cloth filter (#10-334).
- Round brush nozzle (#10300-11B).
- Wet nozzle (#10300-35B).



10-700 M1

**\$929.99**

reg. \$1,200.00



#### Down draft table

**Provides a higher level of safety and convenience by collecting dust at the source.** Steel top with rubber grommets to hold and protect the work piece. Two onboard 110 V electrical outlets.